

Microscopy with momentum

2D k-space imaging with PEEM offers a new perspective for surface science analysis.

Marten Patt and Dieter Pohlentz

Photoemission has a history as one of the leading techniques in material and surface science. In the last decade, 2D k-space imaging or „Momentum Microscopy“ has become one of the latest and most promising developments in this field. It allows insight into the electron band-structure of novel material systems, unveiling useful effects that can have a strong impact on future information technology. In combination with real-space imaging, it is the ideal tool to make new materials applicable to next-generation devices.

While initially being the focus of European scientists, interest in Momentum Microscopy has rapidly increased worldwide because of the many high impact scientific publications and the extraordinary technical improvements described therein. Furthermore, the concepts of Momentum Microscopy allow scientists to push achievements in surface and material science towards product relevant applications. For example, a material system applicable to quantum computing that is investigated on a millimetre length scale should also work in nano-structured devices. Momentum Microscopy evolved from real-space photoemission microscopes (Fig. 1) so that the sample surface can be imaged down to the nm-range (real time imaging, no scanning) while simultaneously providing for easy navigation in order to isolate small features that are necessary for subsequent band structure mapping.

Electron momentum in novel material systems

When atoms are combined with molecules or solids, the orbitals of their outermost electrons (valence electrons) overlap and are involved in chemical bonding. In regular ordered atomic structures (e.g., a crystal lattice), those electrons can occupy very specific energy bands. This valence band struc-

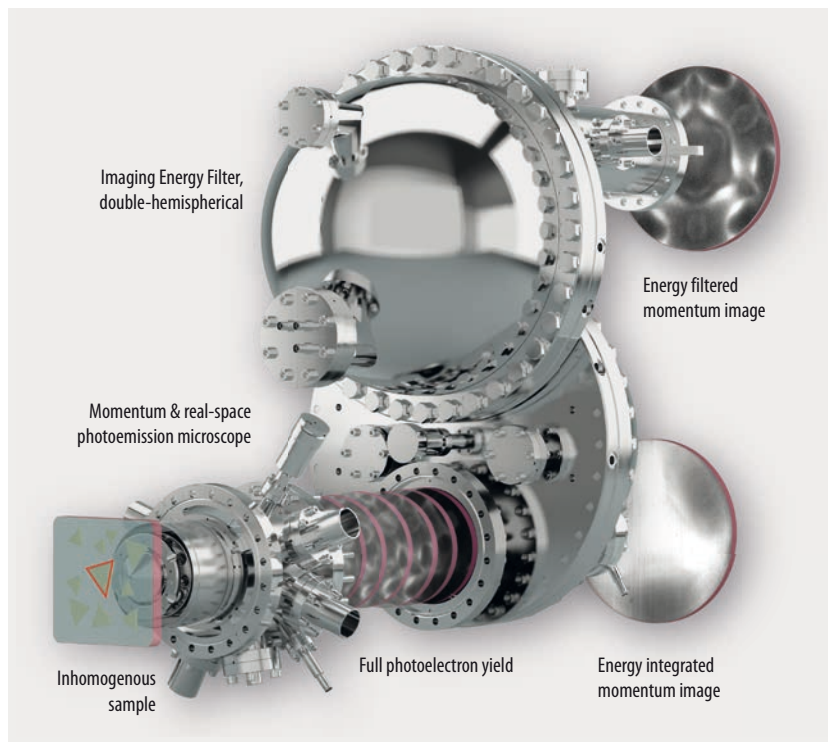

Fig. 1 The NanoESCA is based on the combination of a Photoemission Microscope with an imaging double-hemispherical energy filter (IDEA). It allows for analyzing the electronic band structure of very small features of inhomogeneous and/or structured samples.

ture is specific to each material system and is related to important material properties such as electrical conductivity, optical absorption, and spin transport. It is usually plotted as the binding energy E_{bin} of an electron in the solid versus its lateral momentum (k_x, k_y , Fig. 2).

Band structure is the key to understanding the working principles of nearly all solid-state devices (transistors, microprocessors, LEDs, solar cells, etc.). New material classes including graphene, topological insulators, and transition metal dichalcogenides (TMDs) are examined for their use in future electronic devices. TMDs, especially, are chemically versatile and thus predestined to tune their electronic structure for various applications. A fast band structure mapping becomes essential for device engineering in the future.

A new concept for band structure analysis

The term Momentum Microscopy describes the combination of a photoemission electron microscope (PEEM) with an imaging band-pass energy filter (Fig. 1). For kinetic electron energies up to 40 eV, the microscope collects all photoelectrons emitted into the complete solid angle above the sample surface. For a discrete energy (selected by the band-pass filter), it forms an image of the photoelectron distribution as a function of the lateral momentum (k_x, k_y).

By scanning a range of energy filtered momentum maps, one directly gets a 3D data cube (lateral electron momentum vs. electron binding energy) representing the accessible electronic band structure of the material under investigation (Fig. 2c).

Compared to traditional techniques that use a single hemispherical analyzer, Momentum Microscopy has the advantage of providing a nearly monochromatic electron 2D image at the end of the double-hemispherical energy-filter. For example, it is possible to see a full Brillouin zone for certain energies, (e.g., the Fermi surface) in one shot. In live-view mode, it is possible to navigate through the band structure, zoom into details or adjust apertures. The monochromaticity of the electron image can be used for new technologic approaches like an imaging spin-filter, for which the full image needs to be scattered on a crystal with a defined kinetic energy. Imaging methods dramatically speed up such measurements due to high parallelism.

A brief history of Momentum Microscopy

The instrumental prerequisite for momentum imaging was established in the BMBF funded project “NanoESCA” (through December 2003), which aimed to combine a PEEM with a suitable energy filter to accomplish imaging ESCA (Electron Spectroscopy for Chemical Analysis) on the nano scale. Dietmar Funnemann (Omicron GmbH) and Matthias Escher (FOCUS GmbH) came up with the approach of two adjacent hemispheres, coupled with an inverting transfer lens, as an imaging energy filter. While the first hemisphere is used for energy dispersion, the second one compensates the image aberrations generated by the first one (Fig. 3). This innovative approach has been protected as “Imaging Double Energy Analyser (IDEA)” by a related patent [1].

The first commercial instrument was delivered in 2005 to the CEA Grenoble. It is equipped with a monochromatic and fine-focused X-ray source and was successfully used for chemical imaging of nano-structured samples with unsurpassed lateral resolution [2].

The second instrument was delivered in 2006 to MPI Halle in order to operate this NanoESCA in the momentum space imaging mode [3], after Kotsugi et al. [4] had demonstrated

its feasibility with a FOCUS-PEEM in 2002. This was the hour of birth for the Momentum Microscope.

The next NanoESCA for FZ Jülich was the first one to be permanently used as synchrotron end-station (Elettra, Italy) [5]. This one and all following were equipped with the momentum lens extension from the very beginning. The experience made with those instruments, as well as independent developments at the MPI Halle [6], triggered technical improvements, primarily pushing the energy resolution and the momentum resolution to new levels.

Consequently, new components were developed to expand the possibilities of Momentum Microscopy including a liquid He cooled manipulator for better energy resolution, the HIS 14 (VUV lamp with focusing mirror) for a high photon density, and the HIS 14 monochromator for improved energy resolution. The

NanoESCA delivered 2016 to Bristol University is the first to be equipped with all of these achievements. It is one of the best performing laboratory-based Momentum Microscopes of today.

Micro-ARPES as key-application

Besides the imaging energy-filter, the lens extension of the PEEM, which allows one to image the momentum distribution, is the key feature of the Momentum Microscope. This extended PEEM lens is designed to easily change between real-space imaging and momentum-space imaging by switching the projection lens settings (Fig. 4a, b). At the same time, the electron trajectories in both modes are equal up to the first image plane. This implies the usage of the two different apertures integrated into the PEEM column. The first one at the back focal plane of the objective lens

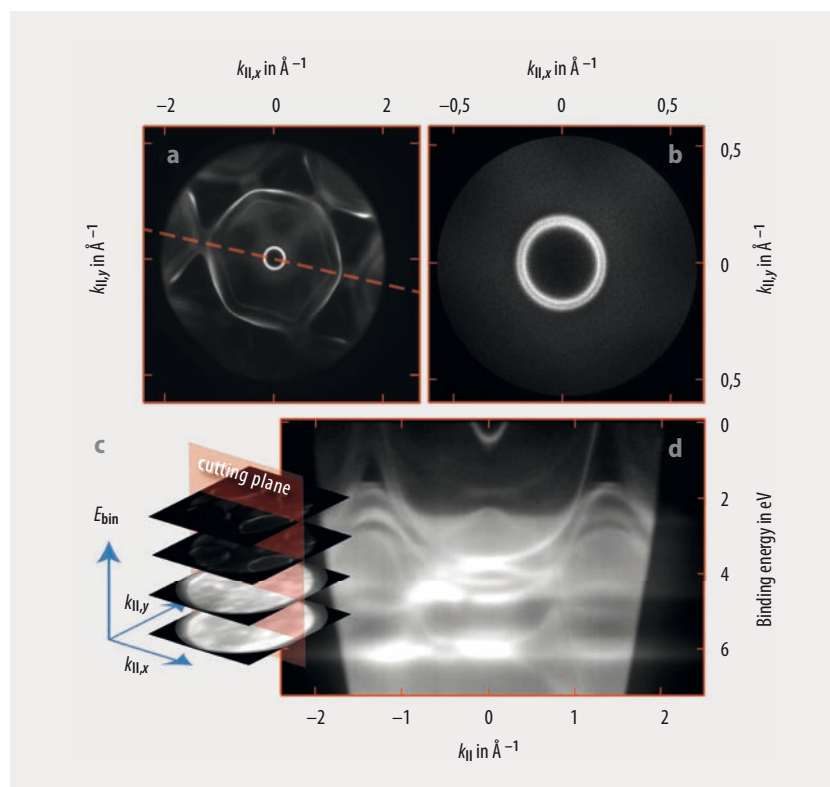

Fig. 2 Momentum Microscopy on a clean Au (111) surface. The overview momentum map of the Fermi energy (a) shows more than a full Brillouin zone, while the zoomed in map resolves features like the Rashba surface splitting. Acquiring these momentum maps for all energies in the valence band leads to a 3D data stack (c), which can be cut in any high symmetry direction (d) to study the band structure of a material. The shown measurements were performed in a laboratory setup with a HIS 14 VUV light source (photon energy 21,18 eV (He I)) and a liquid He cooled manipulator ($T = 30$ K). The energy analyzer was set to 50 meV energy resolution.

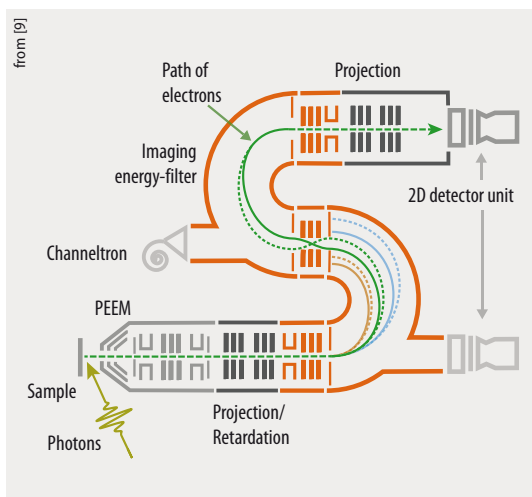

Fig. 3 The PEEM image is projected onto the entrance of the imaging energy-filter. The first hemisphere separates different kinetic electron energies, while the second hemisphere is used to compensate the (spherical) aberrations induced by the first one.

(contrast aperture) restricts the angular acceptance of the microscope. In real-space imaging, the spherical aberration is reduced and thus enhances the resolution of the PEEM. For momentum space imaging, it is typically fully open. The second aperture is an iris aperture to define a small emitting area on the sample ($< 6 \mu\text{m}$) from which photoelectrons are measured in momentum mode (**Fig. 4c**).

The work-flow of micro-ARPES includes finding special features on the sample surface, isolating them by closing the iris aperture around them, and then switching to momentum-space mode to complete band structure imaging from a well-defined spot on the sample. This technique does not depend on the beam spot of a light source like conventional ARPES or imaging XPS, which uses a scanning beam spot. To search for features on the sample in real-space mode, the field of view can be zoomed from $800 \mu\text{m}$ in diameter to $6 \mu\text{m}$.

Micro-ARPES on novel material systems

One exciting application for micro-ARPES is the study of Transition Metal Dichalcogenides (TMDs). Many of those grow as small monolayers of two-dimensional crystals. **Fig. 5** shows an example of WSe_2 grown on graphite. The sample has been heated to $400 \text{ }^\circ\text{C}$ for several hours for cleaning. The crystals show a strong chemical contrast against the graphite at a binding energy of 1.8 eV . Local photoemission spectra taken from an energy-filtered real-space data cube show the spectral differences between crystal and substrate. For

Momentum Microscopy, the iris was closed to restrict the acquired signal to the crystal. The measurement of the full valence band took approximately one hour.

Imaging Spin Filter with Momentum Microscopy

An innovative technique in combination with the Momentum Microscope is to use the monochromatic electron distribution behind the unique double-hemispherical analyzer of the NanoESCA to retard it to the needed scattering energy of a $\text{W}(100)$ or an $\text{Ir}(100)$ single crystal. This allows for spin-polarization dependent reflection. **Fig. 6** demonstrates how this technique was used to separately detect majority and minority spin-states in a thin cobalt film (grown on $\text{Cu}(001)$) to study the interplay between band structure, magnetism and many-body correlations in magnetic materials and to improve the knowledge about magnetism itself [7].

These experiments were performed at the NanoESCA end-station at synchrotron Elettra [5], demonstrating its extraordinary capabilities as one of the most promising spin- and momentum-resolved photoemission instruments available.

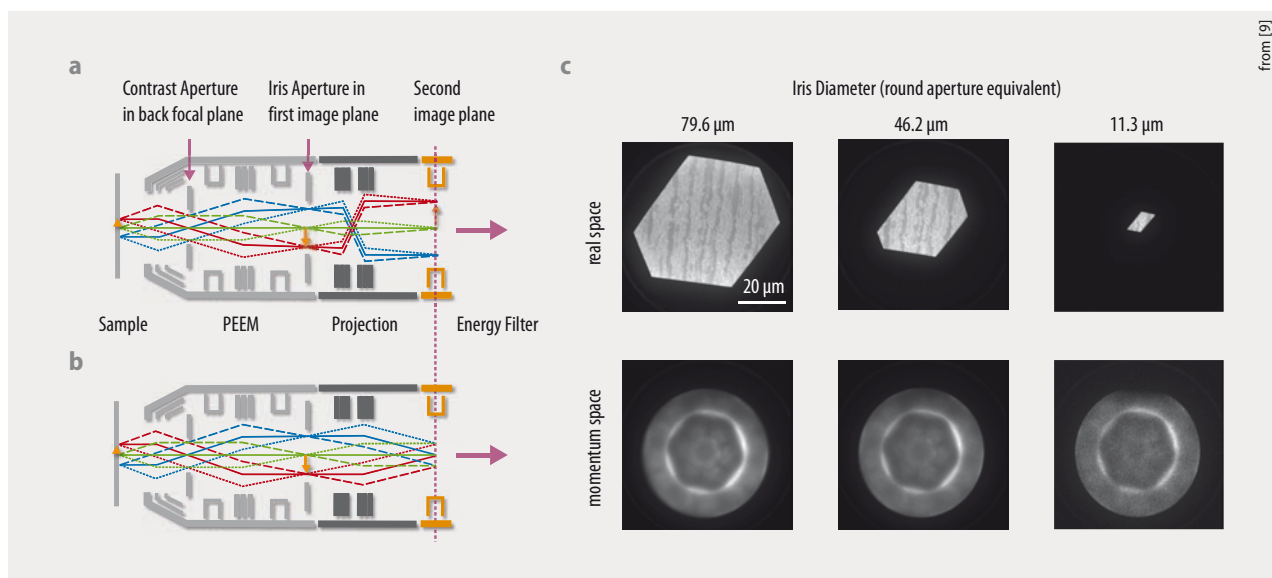

Fig. 4 The PEEM column can be easily changed between real-space imaging (a) and momentum-space imaging (b) by adjusting the projection lenses. The electron trajectories of both settings are equal up to the first imaging plane to allow a reliable positioning of the apertures. The iris aperture in the first image plane can be used to define a small spot on the sample surface (c), from which the momentum-space data can be acquired (d). All shown images were acquired in a 10 s exposure time. The signal is strong enough to see the structures in live-mode (500 ms exposure time) for navigation. The shown images were acquired on a monolayer of graphene on SiC.

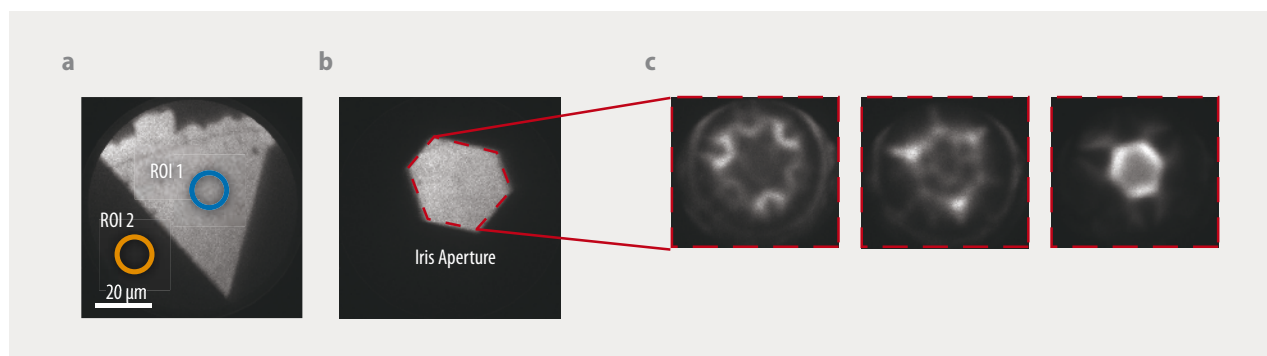

Fig. 5 A WSe_2 monolayer crystal (on a 5 mm x 5 mm graphite substrate) was localized in real-space imaging mode (a). The NanoESCA was set to an energy with a high chemical contrast between the crystal (blue) and the graphite substrate (orange). The iris aperture was closed to isolate the signal coming from the crystal (b) and momentum images (c) were acquired along the valence band.

Conclusion and outlook

A PEEM column which projects the full angular electron distribution of a photoemission experiment in combination with an electrostatic double-hemispherical imaging energy-analyser makes Momentum Microscopy one of the most promising concepts for surface and material science of the next decade. The 2D mapping of the complete electron momentum distribution at the Fermi level is extremely interesting for novel materials (graphene, topological insulators, TMDs) and will play an important role in the next generation of devices (e.g., quantum computing). Engineering functional devices from these new material systems requires an easy switching between real- and momentum space, while the live-imaging ability is the key for an easy and controlled workflow.

Although the concept of Momentum Microscopy is relatively new in the history of photoemission, big steps in the improvement of relevant specifications, like momentum and energy resolution, were achieved in the last years and will benefit from ongoing continuous improvement. On top of this, the new concept enables the development and use of new creative inventions, like the imaging spin-filter, or new methods, like the reconstruction of molecular orbitals [8].

- [1] D. Funnemann and M. Escher, European Patent EP 1 559 126 B1
- [2] O. Renault et al., J. Electron Spectrosc. Relat. Phenom. **171**, 68 (2009)
- [3] B. Krömker et al., Rev. Sci. Instrum. **79**, 053702 (2008)
- [4] M. Kotsugi et al., Rev. Sci. Instrum. **74**, 5 (2003)
- [5] C. M. Schneider et al., J. Electron Spectrosc. Relat. Phenom. **185**, 330 (2012)

- [6] C. Tusche et al., Ultramicroscopy **159** (2015)
- [7] C. Tusche et al., Nature Comm. **9** 3727 (2018)
- [8] M. Wiefßner et al., Nature Comm. **5** 4156 (2014)
- [9] M. Patt, PHD thesis, <http://hdl.handle.net/2128/10192>

Authors

Dr. Marten Patt, Scienta Omicron GmbH, Limburger Str. 75, 65232 Taunusstein, Germany, www.scientaomicron.com
Dieter Pohlentz, FOCUS GmbH, Neukirchner Str. 2, 65510 Huenstetten, Germany, www.focus-gmbh.com

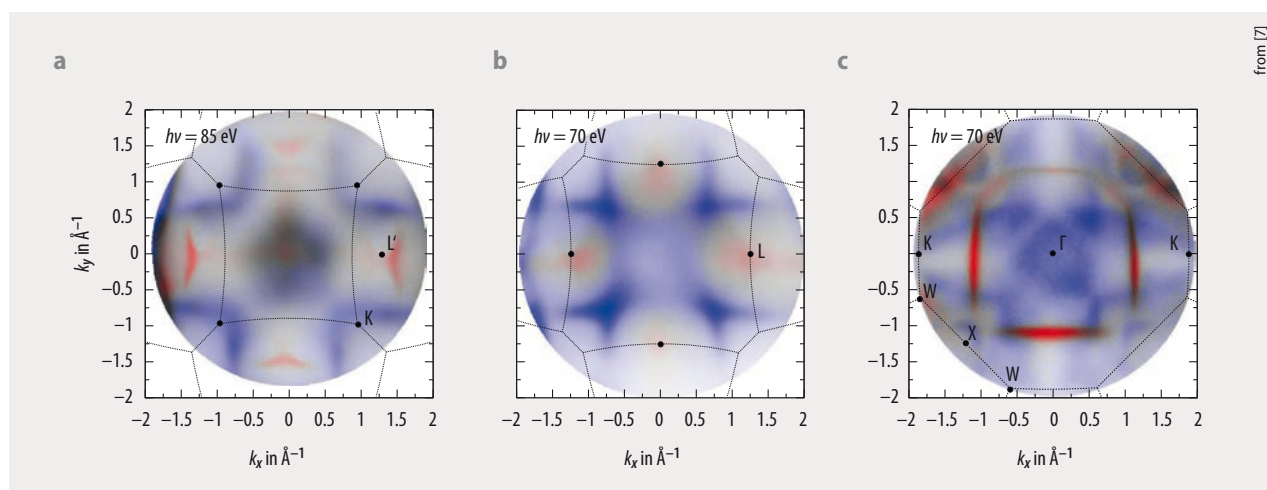

Fig. 6 Measured spin-resolved Fermi surface of fcc cobalt. Spin-resolved photoemission intensities in selected sections through the three-dimensional Fermi surface of 18 ML Co/Cu(100) measured at photon energies of $h\nu = 85$ eV (a), $h\nu = 70$ eV (b), and $h\nu = 50$ eV (c).